

LEGIONELLA RISK ASSESSMENT



Geo Tag: ,
Customer: Believe Housing
Site: Coast House Spectrum 4 Spectrum Business Park Seaham , SR7 7TT
Date: 2nd February 2024
Risk Assessor: Carleton Waite
Report No: J052353 - 664702

Copyright © 2020 by HBE. All rights reserved.

Information and images contained within this report published by Healthy Buildings Ireland Ltd trading as HBE are subject to copyright and the property of HBE.

HBE authorises you to copy documents or pages published by HBE in this report for your organisation's internal use only. Any such copy shall retain all copyrights and other proprietary notices, and any disclaimer contained thereon. None of the content, format or layout of these pages may be photocopied, incorporated into, reproduced on, or stored in any other document, website, electronic retrieval system, or be incorporated in any other publication, including tender documentation, whether in hard copy or electronic form. You may not, without our express written permission, reproduce the information contained within this report, modify or re-use text or graphics used in this report. For permission requests, write to the publisher, addressed "Attention: Legal Department," at the address below.

Group Admin Head Office:
Craigmore House,
19 Millvale Road,
Newry,
Co. Down
BT35 7NH

Contents

1	Introduction	4
1.1	General Introduction and Survey Objectives	4
1.2	Relevant Legislation and Normative References	5
1.3	Executive Summary	7
1.4	Allocation of Risk Rating	9
1.5	Scope and Application of Risk Assessment	14
1.6	Risk Assessment Handover	15
2	Overview of Site	16
2.1	Site Details	16
2.2	Lines of Communication	17
2.3	Record Systems	20
3	Recommendations and Requirements	22
3.1	Remedial Action to Water Systems	22
4	Appraisal of Water Systems	24
4.1	Overview of Water Systems	24
4.2	Water System Details	28
5	Testing of Water Systems	104
5.1	Water Temperature Measurements	104
6	Appendices	105
6.1	List of Abbreviations and Acronyms	105
6.2	Additional Certification	3
6.3	Schematic Drawings	4
6.4	Legionella Escalation Procedure	5
6.5	Action to take if there is an outbreak of Legionellosis	6

1 Introduction

1.1 General Introduction and Survey Objectives

Legionellosis is the collective term used to describe the group of diseases caused by Legionella bacteria. Legionellosis is contracted by inhaling the bacteria contained in aerosols from contaminated water systems.

There is a chain of events (Causal Chain) leading to an individual becoming infected with Legionellosis:

- | The water system needs to become contaminated with the bacteria
- | Conditions have to exist within the water system for the amplification of the bacteria to sufficient concentrations to cause infection
- | The contaminated water usually needs to be dispersed into droplets fine enough to form an aerosol for transmission into the lungs
- | Inhalation of contaminated aerosols or, in rare cases, aspiration of contaminated water

If exposed individuals have a suppressed or depleted immune system they will be more susceptible to infections.

HBE have completed this Risk Assessment in accordance with the UK Health & Safety Executive recommendations contained within the document '*Legionnaires' disease – The control of Legionella bacteria in water systems – Approved code of practice & guidance' on Regulations L8 (Fourth edition), HSG 274 Part 1–3 and Health Protection Surveillance Centre, National Guidelines for the Control of Legionellosis in Ireland, 2009.*

The objectives of this survey are as follows:

1. To enable the responsible person to make an informed decision regarding the adequacy of precautions currently in place to minimise the risk to health from Legionellosis to both building occupants and the general public.
2. To provide documented evidence as to the state of the water systems, control systems and management structure at the time of the assessment.
3. To provide guidance and recommendations on how to control and minimise future risk of Legionella proliferation by:
 - | Identifying and assessing likely sources of risk
 - | Recommending schemes to help control the risk
 - | Suggesting a suitable routine monitoring programme
 - | Checking current record keeping procedures
 - | Clarifying lines of responsibility
 - | Identifying training deficiencies
 - | Providing recommendations
4. It also enables the person on whom the statutory duty falls to demonstrate that all the pertinent factors, and the steps needed to prevent or minimise the risk, have been considered.

1.2 Relevant Legislation and Normative References

This survey has been completed by HBE with reference to current legislation and best practice guidelines. The specific legislation that is referred to in this report includes:

England / Scotland / Wales

1. The Health & Safety at Work Etc. Act 1974.
2. The Control of Substances Hazardous to Health Regulations 2002 (COSHH).
3. The Management of Health and Safety at Work Regulations 1999.
4. The Notification of Cooling Towers and Evaporative Condensers Regulations 1992.

Northern Ireland

1. The Health & Safety at Work (Northern Ireland) Order 1978.
2. The Control of Substances Hazardous to Health Regulations (Northern Ireland) 2003 (COSHH [NI]).
3. The Management of Health & Safety at Work Regulations (Northern Ireland) 2000.
4. The Notification of Cooling Towers and Evaporative Condensers Regulations 1992.

Republic of Ireland

1. Statutory Instrument (S.I.) No. 10 of 2005 – The Safety, Health and Welfare at Work Act 2005.
2. Statutory Instrument (S.I.) No. 299 of 2007 – The Safety, Health and Welfare at Work (General Applications) Regulations 2007.
3. Statutory Instrument (S.I.) No. 619 of 2001 – The Safety, Health and Welfare at Work (Chemical Agents) Regulations 2001.
4. Statutory Instrument (S.I.) No. 572 of 2013 – The Safety, Health and Welfare at Work (Biological Agents) Regulations, 2013.
5. Statutory Instrument (S.I.) No. 370 of 2016 – The Safety, Health and Welfare at Work (Reporting of Accidents and Dangerous Occurrences) Regulations 2016.

Guidance

1. HSE document L8 (Fourth edition) – Legionnaires Disease, The control of Legionella bacteria in water systems: Approved Code of Practice and Guidance on Regulations.
2. HSE document HSG274 Part 1 – The control of Legionella bacteria in evaporative cooling systems.
3. HSE document HSG274 Part 2 – The control of Legionella bacteria in hot and cold water systems.
4. HSE document HSG274 Part 3 – The control of Legionella bacteria in other risk systems.
5. National Guidelines for the Control of Legionellosis in Ireland, Published by Health Protection Surveillance Centre (HPSC), 2009.
6. BS 8580-1:2019 Water quality. Risk assessments for Legionella control. Code of Practice.
7. BS 8558:2015 - Guide to the design, installation, testing and maintenance of services supplying water for domestic use within buildings and their curtilages.
8. BS 8554:2015 - Code of practice for the sampling and monitoring of hot and cold water services in buildings.
9. BS PD 855468:2015 - Guide to the flushing and disinfection of services supplying water for domestic use within buildings and their curtilages.
10. TM 13:2013 CIBSE Technical Memorandum - Minimising the Risk of Legionnaires Disease.
11. WMSoc Guidance Documents.
12. UK HSE document “Working safely with metalworking fluids - good practice manual” (2011).
13. BS 7592:2022 Sampling for Legionella bacteria in water systems - code of practice.
14. HSE document HSG 282 The control of Legionella and other infectious agents in spa-pool systems.
15. The Water Supply (Water Quality) Regulations 2010.
16. The Water Supplies (Water Quality) (Scotland) Regulations 2011.
17. The Water Supply (Water Fittings) Regulations 1999.
18. BSEN 671-1-2012 Fixed Fire Fighting Systems.
19. BSEN12845-2004-A2-2009 Fixed Fire Fighting Systems Design and Maintenance.
20. BSEN 806-1 Specification for installations inside buildings conveying water for human consumption.
21. ANSI Z 358.1 2009 Drench Showers, Eyewash, Eye / Face Wash, Portable Eyewash, and Combination Eyewash & Drench Shower units.
22. Water for Scotland 2nd Edition.
23. Private Water Supply Scotland: Technical manual.

1.3 Executive Summary

HBE have been contracted by Believe Housing to carry out a comprehensive Legionella and Water Hygiene Risk Assessment on domestic water systems within Coast House Spectrum 4 Spectrum Business Park Seaham, SR7 7TT as directed by the customer, in accordance with the HSE Approved Codes of Practice & Guidance on Regulations document L8 (*Fourth edition*): *the control of Legionella bacteria in water systems / HSG 274 / National Guidelines for the Control of Legionellosis* in Ireland, Published by Health Protection Surveillance Centre (HPSC), 2009 and Believe Housing tender / order specification.

At present full lines of communication for the Duty Holder, Responsible Person and Deputy Responsible Person involved in the implementation of the legionella control scheme have been put in place.

Site personnel involved in the implementation and undertaking tasks associated with a legionella control scheme have been appropriately trained for their role.

Currently there is a legionella risk control scheme in place within these premises. It is essential that this is fully implemented to reduce the actual legionella risk associated with the water systems on this site.

Remote Monitoring (RM) is currently active on this site. Including all domestic pipework associated with the Calorifier.

All incoming mains water supply distribution temperatures were considered satisfactory for legionella control at the time of the assessment, at below 20°C.

All hot water outlets achieved at least 50°C within 1 minute; this is adequate for Legionella control.

Water heaters (15L or below) were found to be successfully heating water to or in excess of the minimum required temperature of 50°C.

Diaphragm/bladder expansion vessels were identified on site. Diaphragm/bladder expansion vessels represent potential deadlegs within which stagnant water can accumulate thereby creating an environment that is more favourable for microbial growth. It is essential then that such expansion vessels are fitted with a drain valve to allow the vessel to be flushed and that flushing is undertaken on at least a six-monthly basis.

Flexible pipework was noted as being present on various outlets. Low quality non-WRAS approved flexible pipework has been previously identified as harbouring and supporting the proliferation of contaminating micro-organisms. Clarification is required over whether this flexible pipework is WRAS approved.

Scale was noted on a number of outlets. Scale can harbour and provide nourishment for contaminating micro-organisms. The scale should be removed completely with regular inspections and cleaning thereafter.

Aerators/Flow Straightener inserts were noted on a number of outlets. These can create greater potential for aerosol production during normal use and have also been identified as harbouring small droplets of water within which bacteria can proliferate. Consideration should be given to their removal.

A number of showers were identified. As showers produce significantly more aerosols, the most common vector for Legionella transmission, this type of outlet must be inspected quarterly and descaled and disinfected when required.

A number of temperature mixing valves have been installed on site. Whilst these valves assist in blending water to minimise the potential for users being scalded, they can harbour and provide a favourable environment for microbial growth. It is essential that these valves are inspected and maintained on an annual basis.

Refer to table 3.1 Remedial Action to Water Systems for further details!

Introduction

The risk assessment has been carried out with an asset register provided by HBE.

Water systems found at Coast House Spectrum 4 Spectrum Business Park Seaham are captured in table *4.1 Overview of Water Systems*.

1.4 Allocation of Risk Rating

Items of plant constituting a risk to health have an Inherent Risk and an Actual Risk. The aim of a complete Risk Assessment is to firstly identify all plant with an inherent risk and then make an assessment of its actual risk.

In making a valued assessment of the actual risk condition of the plant, maintenance procedures, location, compliance with current guidelines and codes of practice should all be examined.

Inherent Risk Rating

Each risk assessment should be accompanied by an explanation of the inherent risk, with the actual risk reported and based on the grading system below. This should enable the responsible person to prioritise future actions.

Minimal Risk	Low Risk	Medium Risk	High Risk	Very High Risk

In general terms the following broad categories may apply:

i.	<u>Very High Risk System:</u>	A very high risk system is one where high aerosol release such as cooling water systems and spa baths if found.
ii.	<u>High Risk System:</u>	A high aerosol generation systems such as showers, spray booths, fountains and humidifiers if found.
iii.	<u>Medium Risk System:</u>	Stored water systems such as cold water storage tanks, calorifiers, combination water heaters if found.
iv.	<u>Low Risk System:</u>	Mains water systems, with minimal storage and without aerosol generators if found.
v.	<u>Minimal Risk System:</u>	Mains water systems, without storage and without aerosol generators if found.

Risk Type	Risk Rating
Inherent risk	Low Risk

Actual Risk

Accompanying each section of the assessment should be the recommendations to minimise the actual risk, these may involve changes to the plant and upgrading maintenance regimes and documentation procedures amongst others. The conclusions and recommendations contained in this assessment are based upon information supplied by the Site's responsible person and/or his/her deputies.

	Very High Risk / Category 1 To be completed as soon as reasonably practicable
	High Risk / Category 2 To be completed as soon as reasonably practicable
	Medium Risk / Category 3 Implementation within 6 months
	Low Risk / Category 4 Implement within 12 months
	Minimal Risk / Category 5 To be completed during next plant shut down or where budgetary restrictions allow.

Should further information subsequently become available which may impact on this assessment, a review of the assessment may be required.

This report has determined the risk rating from the water systems below. The scoring takes into account factors such as severity of plant present, persons exposed, the written scheme, system condition and any relevant training.

This highlights the importance of effective *HSG 274 / L8 based* and *HPSC* risk management programme. In the case of Coast House Spectrum 4 Spectrum Business Park Seaham the risk is managed by implementation of an *HSG 274 / L8* and *HPSC* monitoring programs for water systems.

Risk Factors	Risk Rating
Population Vulnerability Potential	Low
Aerosol Exposure Risk	Medium
Proliferation Risk	Low
Management of the water systems	Low

Asset Type	Risk Rating
Calorifiers CAL 1	High
Drinking Water Dispensers / Ice Machines / Vending Drinking Water Dispenser	Low
Flexible Hose Connectors FH1	Medium
Flexible Hose Connectors FH10	Medium
Flexible Hose Connectors FH11	Medium
Flexible Hose Connectors FH12	Medium
Flexible Hose Connectors FH13	Medium
Flexible Hose Connectors FH14	Medium
Flexible Hose Connectors FH15	Medium
Flexible Hose Connectors FH16	Medium
Flexible Hose Connectors FH17	Medium
Flexible Hose Connectors FH2	Medium
Flexible Hose Connectors FH3	Medium
Flexible Hose Connectors FH4	Medium
Flexible Hose Connectors FH5	Medium
Flexible Hose Connectors FH6	Medium
Flexible Hose Connectors FH7	Medium
Flexible Hose Connectors FH8	Medium
Flexible Hose Connectors FH9	Medium
Filters FIL1	Low

Asset Type	Risk Rating
Filters FIL2	Low
Filters FIL3	Low
Filters FIL4	Low
Filters FIL5	Low
Filters FIL6	Low
Mains water supply MAINS 1	Low
Expansion / Pressure Vessels / Pump Accumulators PV1	High
Expansion / Pressure Vessels / Pump Accumulators PV2	High
Expansion / Pressure Vessels / Pump Accumulators PV3	High
Showers SH1	Low
Showers SH2	Low
Showers SH3	Low
Showers SH4	Low
Showers SH5	Low
Scale on Taps SOT1	Medium
Scale on Taps SOT10	Medium
Scale on Taps SOT11	Medium
Scale on Taps SOT12	Medium
Scale on Taps SOT13	Medium
Scale on Taps SOT14	Medium
Scale on Taps SOT2	Medium
Scale on Taps SOT3	Medium
Scale on Taps SOT4	Medium
Scale on Taps SOT5	Medium
Scale on Taps SOT6	Medium
Scale on Taps SOT7	Medium
Scale on Taps SOT8	Medium
Scale on Taps SOT9	Medium
TMVs TMV1	Low
TMVs TMV2	Low

Asset Type	Risk Rating
TMVs TMV3	Low
TMVs TMV4	Low
TMVs TMV5	Low
TMVs TMV6	Low
TMVs TMV7	Low
TMVs TMV8	Low
TMVs TMV9	Low
Water Heaters WH1	Low
Water Heaters WH2	Low
Water Heaters WH3	Low

RA Review Within	Risk Rating
2 year	Medium

It is recommended that this site be reviewed no later than 02/02/2026.

1.5 Scope and Application of Risk Assessment

HBE have been contracted by Believe Housing to carry out a comprehensive Legionella and Water Hygiene Risk Assessment on domestic water systems within Coast House Spectrum 4 Spectrum Business Park Seaham . The Office block is currently in use.

Carleton Waite of HBE conducted this Risk Assessment on the 2 Feb 2024. Carleton Waite has completed Legionella specific training such as the WMSoc, City & Guilds and BOHS P901. HBE ensure, through appropriate training, that surveyors have the appropriate instruction, information, resources and equipment to carry out risk assessments in a competent and safe manner. Certification for training is included in the appendices of this report.

Site should ensure that suitable control measures are in place and that all recommendations are completed to ensure that the risk from all systems is controlled.

Limitations of Survey

Although every care is taken to detect all relevant pipe work and systems on site, it is possible that some elements may remain hidden from inspection (e.g. dead legs and underground pipes) and shall be detailed in the executive summary.

This Risk Assessment is the considered opinion of the consultant involved, based on the evidence found at the time of inspection, and covers only the systems and facilities listed within.

Since supply water quality, weather conditions and several other factors will vary over the course of time and as a result of seasonal changes, the findings of this study and resultant recommendations should be taken in the context of the current situation. Future conditions may lead to the establishment of significantly different risk levels.

Neither HBE nor its representatives are qualified to offer any medical opinion regarding Legionella based diseases or the likely effects of any particular level of bacteria on site.

NOTE

Any property that has a prolonged shutdown (greater than 1 week) must ensure that a weekly flushing programme is implemented to replicate normal water usage. i.e. school closed during summer holidays or sports pavilions during off season.

1.6 Risk Assessment Handover

HBE have provided an independent assessment to this customer, and have highlighted the requirements and recommendations to control the risk from Legionella. It is the responsibility of the customer to ensure the full implementation of all remedial work and recommendations on site.

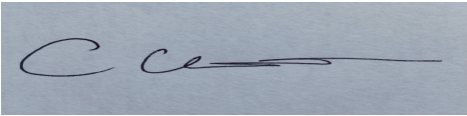
HBE Legionella Risk Assessor Signature
Carleton Waite 
Legionella Risk Assessor Name
Date: 2nd February 2024

The record of the assessment is a living document that should be reviewed to ensure it remains up-to-date. Arrange to review the assessment regularly and specifically whenever there is reason to suspect it is no longer valid. An indication of when to review the assessment and what to consider should be recorded.

This may result from, e.g.:

- (a) Changes to the water system or its use;
- (b) Changes to the use of the building in which the water system is installed;
- (c) The availability of new information about risks or control measures;
- (d) The results of checks indicating that control measures are no longer effective;
- (e) Changes to key personnel;
- (f) A case of legionnaires' disease/legionellosis associated with the system.

See ACOP, L8 (Fourth edition) Para 47 and HPSC, Legionella Guidelines 2009, Chapter 5.

2 Overview of Site

2.1 Site Details

Building use:	Offices
Frequency of use:	Daily

Occupancy Levels

Number of Occupants and Potential Contractors:	500
Is Building Open to General Public?	No
Susceptible Groups:	<p>Present</p> <p>While previously healthy people may develop legionnaires' disease, there are a number of factors, which increase susceptibility:</p> <ul style="list-style-type: none"> Increasing age, particularly above 45 years; Newborn infants; Gender: males are three times more likely to be infected than females; Existing respiratory disease which makes lungs more vulnerable to infection; Illnesses, such as cancer, diabetes, kidney disease or alcoholism, which weaken the natural defences; Smoking, particularly heavy cigarette smoking, because of the probability of impaired lung function; Patients on renal dialysis or immune-suppressant drugs, which inhibit the body's natural defences against infection. <p>While the above risk groups may not be present on this site it is vital for the Health and Safety of all occupants, visitors and residents that risk systems are operated in a manner which reduces any potential risk as outlined in this survey.</p>

2.2 Lines of Communication

Inadequate management, lack of training and poor communication have all been identified as contributory factors in outbreaks of Legionnaires' disease. This is particularly important where several people are responsible for different aspects of the treatment or precautions.

Legislative Requirements

If you are an employer or a person with responsibilities for control of premises, you are defined as the dutyholder and you have legal responsibilities for the health and safety of employees and non-employees affected by your work activities.

The principal legislation that applies are the (UK) Health and Safety at Work etc. Act 1974, COSHH 2002 and the Management of Health and Safety at Work Regulations 1999; (NI) The Health and Safety at Work Order 1978, COSHH 2003 and The Management of Health and Safety at Work Regulations 2000, Statutory Instrument (S.I) The Safety, Health and Welfare at Work Act No. 10 of 2005, At Work (General Applications) No. 299 of 2007, At Work (Chemical Agents) No. 619/2001, At Work (Biological Agents) No. 572 of 2013, At Work (Reporting of Accidents and Dangerous Occurrences) No. 370 of 2016.

Responsibilities

The ACoP / HPSC states that, if you are the dutyholder, to comply with your legal duties you should:

- | Identify and assess sources of risk in a written risk assessment
- | Appoint a person to be managerially responsible for the water system
- | Prepare a written scheme for preventing or controlling the risk
- | Implement and manage precautions
- | Keep records of the precautions

In addition, the ACoP / HPSC sets out the responsibilities of suppliers of services such as water treatment and maintenance as well as manufacturers, importers and installers.

In law you are not required to do everything that is contained in the ACoP / HPSC but you should do all that is reasonably practicable to eliminate or control a foreseeable risk of people being exposed to Legionella bacteria within an aerosol. If you fail to follow the guidance in the ACoP and accompanying HSG274 / HPSC or do not implement equivalent control measures you are likely to be subject to enforcement action by the HSE / HSA or your local Environmental Health Officer. You do not have to cause cases of Legionnaires' disease to be liable for prosecution under the HSWA or COSHH. You can be prosecuted for failing to implement reasonable measures to prevent or control the risk or because of a failure of the control measures that could lead to exposure to Legionella bacteria.

Communications should be 'fail-safe'. The record system is the method to ensure that precautions continue to be carried out and that information is available for checking what is done in practice.

ACOP L8 (Fourth edition) Paragraphs 48 - 51 and HPSC, Legionella Guidelines 2009 Chapter 5 highlights the requirement for identified lines of communication and a clear structure of responsibility, which should be put in place to ensure competent management of the risk management program.

Risk Rating	
Management and Written Scheme Risk Rating	Low

Overview of Site

Duty Holder: The person on whom the statutory duty falls. The duty holder has overall responsibility for the Legionella program and should appoint a responsible person to supervise the day to day running of all Legionella related issues (*ACOP L8 (Fourth edition), Para 48*) and *HPSC, Legionella Guidelines 2009, Chapter 5*).

Name	Alan Smith
Position	Position Chief Executive
Telephone Number	0191 814 2854
Mobile Number	07894 838649
E-mail address	alan.smith@believehousing.co.uk

Responsible Person: Appointed by the statutory duty holder. The responsible person is charged with responsibility for implementing the risk assessment recommendations and the Legionella risk management program. The responsible person reports to the duty holder (*ACOP L8 (Fourth edition), Para 51*) and *HPSC, Legionella Guidelines 2009, Chapter 5*).

Name	Emma Jorgenson
Position	Compliance Manager
Telephone Number	0191 814 2900
Mobile Number	07384 523636
E-mail address	emma.jorgenson@believehousing.co.uk

Deputy Responsible Person: Appointed by the statutory duty holder or responsible person. The deputy responsible person is charged with responsibility for implementing the risk assessment recommendations and the Legionella risk management program in the absence of the responsible person.

Name	Andrew Graham
Position	Compliance Officer
Telephone Number	03001 311999
Mobile Number	07901 510712
E-mail address	andrew.graham@believehousing.co.uk

Site Contact: Appointed by the responsible person. Point of contact between site and water treatment specialists/consultants. Involved in the day to day running of the risk management program. Person nominated by site to give assistance and information on day of survey.

Name	Andrew Graham
Position	Compliance Officer
Telephone Number	03001 311999
Mobile Number	07901 510712
E-mail address	andrew.graham@believehousing.co.uk

Overview of Site

Water Treatment Company: Appointed by the duty holder. The water treatment company provides information on current legislation and industry best practice in relation to Legionella. May also be required by site to implement management programmes, provide chemical dosing programmes and technical support.

Company Name

Name	HBE UK & Ireland
System Involved	Domestic
Telephone Number	0333 207 5744
Mobile Number	N/A
E-mail address	http://enquiries@hberm.com/

Water Hygiene Consultants: Appointed by the duty holder/water treatment company to complete the Legionella risk assessment on site. The water hygiene consultant provides information on current legislation and industry best practice in relation to Legionella. May also be required by site to implement management programmes, provide chemical dosing programmes and technical support.

HBE Account Manager

Name	Lloyd Neary
Position	Account Manager
Telephone Number	0845 6399673
Mobile Number	07885 969616
E-mail address	l.neary@hberm.com

HBE Legionella Risk Assessor

Name	Carleton Waite
Position	Legionella Risk Assessor
Telephone Number	
Mobile Number	07515993281
E-mail address	carleton.waite@hberm.com

Lines of Communication Information Received From

Name	Andrew Graham
Position	Compliance Officer

Cooling Water System Records/Information Received From

Name	N/A
Position	N/A

Leisure Centre Information Received From

Name	N/A
Position	N/A

Legionella Monitoring Scheme - Domestic Water

Where a scheme of control is in place, HBE risk assessors shall undertake a detailed appraisal and audit of the scheme and report on its adequacy. In order to ensure that the risks from legionella are controlled, *HSG 274 Part 2 and HPSC, Legionella Guidelines 2009* recommends that a programme of checks, inspections and monitoring of the risk systems be put in place. Detailed below are these tasks and their scheduled frequencies for domestic water systems. Where this survey has found that an item is not completed, or completed at an inadequate frequency, site shall implement remedial action to ensure the appropriate checks and tests are in place for an adequate system of control, as recommended by *HSG 274 Part 2 Table 2.1* and *HPSC, Legionella Guidelines 2009, Table 4*.

Details are specified in the table below. Any actions required by site are detailed in Section 3.

Action	Frequency	Currently Carried Out On Recommended Interval
Measure Temperature of Sentinel Outlets Cold / Hot	Monthly	Contractor
Measure Temperature of Calorifier / PHE Flow	Monthly	Contractor
Measure Temperature of Calorifier / PHE Return	Monthly	Contractor
TMV Sentinel Temperature Checks	Monthly	Contractor
Measure Temperatures of Water Heater	Monthly	Contractor
Flushing of Expansion Vessels	Monthly	Contractor
Descale Clean and Disinfect Shower Heads (Inc. Spray nozzles on IWH)	Quarterly	Contractor
Inspection and servicing of TMV's	Annually	Contractor
Measure Temperature of Incoming Mains	Annually	Contractor
Measure Temperature of Representative Selected Outlets	Annually	Contractor
Flush Calorifier Drain to Indicate Internal Condition	Annually	Contractor
Internal Inspection of Calorifier	Annually	Contractor
Review Meeting With Customer	Annually	Client
Disinfect Hot and Cold System (Remedial Action)	Annually	Contractor
Clean and Disinfect Calorifier (Remedial Action)	Annually	No
Review Results	Annually	Client

Inspection of Record Systems - Domestic Water

An assessment of the risk should be carried out and those appointed shall record the significant findings and ensure appropriate records are kept as highlighted in *ACOP L8 (fourth edition)* and *HPSC, Legionella Guidelines 2009*. This should include any groups of employees identified as being particularly at risk and the steps taken to prevent or control risks. If the employer has less than five employees there is no statutory duty to write anything down, but it may be useful to keep a written record of what has been done.

Item	Information	Satisfactory Yes/No	Reference Source
Management Structure / Lines Of Communication	Do persons responsible for water hygiene and safety have responsibilities detailed in writing?	Yes	Electronic Records Held
Suitable Record Keeping	Are records relating to water hygiene and control scheme documents located centrally?	Yes	Electronic Records Held
Written Control Scheme In Place	Is there a written control scheme in place and implemented fully?	Yes	Electronic Records Held
Where System Drawings Available – Where Are They Located	Are schematic drawings available?	Yes	Current Risk Assessment
Site Visits And Inspections	Are site visits relating to water hygiene logged?	Yes	Electronic Records Held
Cleaning And Disinfection Records	Are disinfection records held on site?	Yes	Electronic Records Held
Training Records Of Personnel	Are training records held on site?	Yes	Electronic Records Held
Training Records For All Positions	Are duty holders training to the standards required? Are staff involved in water hygiene trained to standards required?	Yes	Electronic Records Held
Training Records For Third Party	Are training records held on site?	Yes	Electronic Records Held
Remedial Work Completed And Recorded	Are records kept of any remedial works on site?	Yes	Electronic Records Held
Legionella Risk Assessment	Has a risk assessment been carried out previously?	Yes	Electronic Records Held
Safe Operation Of Risk Systems	Are systems that pose substantial risk operated safely and documentation located on site?	Yes	Electronic Records Held
Water Safety Plan/Policy And Escalation Procedures	Is there a water safety policy created for this site? Is there an adequate written escalation plan to ensure that during an outbreak at this site, or site nearby, that appropriate persons and government bodies are contacted and media and communication requirements covered?	Yes	Electronic Records Held
Calibration Records For Monitoring Thermometers	If site carries out temperature monitoring themselves, do site calibrate their thermometers?	Yes	Temperature Monitoring Contracted

3 Recommendations and Requirements

3.1 Remedial Action to Water Systems

The recommendations of the risk assessment are itemised below. This log should be used to monitor and maintain a signed record of the completion of all recommendations made in the Legionella Risk Assessment. This log should be completed by a person of suitable authority i.e. Duty Holder, Responsible Person or other nominated personnel.

Priority Rating Key:

1. Very High Risk - To be completed as soon as reasonably practicable
2. High Risk - To be completed as soon as reasonably practicable
3. Medium Risk - Implementation within 6 months
4. Low Risk - Implement within 12 months
5. Minimal Risk - To be completed during next plant shut down or where budgetary restrictions allow

System Ref	Temp & Flow	Priority	Assigned To	Comments	Date Completed	Signed
CAL 1	The stored water within the calorifier shall be maintained at greater than 60°C to prohibit bacterial proliferation.	High / Category 2				

System Ref	General	Priority	Assigned To	Comments	Date Completed	Signed
FH1, FH10, FH11, FH12, FH13, FH14, FH15, FH16, FH17, FH2, FH3, FH4, FH5, FH6, FH7, FH8, FH9	At the time of the survey the WRAS approved numbers could not be identified on the flexible hoses, site shall ensure that these are compliant and either replace or pipe in rigid copper.	Medium / Category 3				

System Ref	General	Priority	Assigned To	Comments	Date Completed	Signed
PV1, PV2, PV3	When these units are incorporated into systems a dead leg is created to the pressurisation vessel. Site should	High / Category 2				

Recommendations and Requirements

	<p>ensure the installation of these vessels are as close as possible to the system pipework to minimise the dead leg created. Where there is a run of pipework to the pressurisation vessel a suitable drain should be fitted to enable flushing of the dead leg on a Monthly basis. Alternatively, consider installing a straight through hydraulic accumulator.</p>					
--	---	--	--	--	--	--

System Ref	General	Priority	Assigned To	Comments	Date Completed	Signed
<p>SOT1, SOT10, SOT11, SOT12, SOT13, SOT14, SOT2, SOT3, SOT4, SOT5, SOT6, SOT7, SOT8, SOT9</p>	<p>Site should clean, disinfect and descale taps which are affected on a quarterly basis. This frequency can be reviewed depending on condition of the outlets.</p>	<p>Medium / Category 3</p>				

This risk assessment was conducted by HBE. Whilst every effort has been made to ensure that the assessment has been as comprehensive as possible, it should be recognised that it is impossible to guarantee that every system has been identified and so no liability can be accepted for omissions from this report. Diligence should be maintained in regarding the potential risk of all water systems. If a system is identified which has a potential for harbouring Legionella bacteria, for which no precautions are currently detailed, then HBE should be contacted with a view to advising on the implementation of suitable procedures and updating the risk assessment.

©2020 HBE.

4 Appraisal of Water Systems

4.1 Overview of Water Systems

It is believed that this list is comprehensive, however it should be recognised that it is impossible to guarantee that every system has been identified. It is from inspection of the systems described below that the comments and recommendations in Section 3.1 are made.

Mains Water System

Asset No.	Location	Serving
MAINS 1	Undetermined	Building

Calorifiers

Asset No.	Location	No. of Calorifiers in system	Fed From	Serving
CAL 1	2nd SW - Store	1	Mains	Building

Sentinel Outlet Identification

Supplied from	Sentinel	Location/System Ref
CAL 1	NH - Nearest Hot	2nd NW - Female WC, RM
	FH - Furthest Hot	GF NW - Kitchen, RM
MAINS 1	NC - Nearest Cold	GF NW - Kitchen, RM
	FC - Furthest Cold	2nd NW - Female WC, RM

Domestic Showers & Wash Outlets

Asset No.	Location	Hot Supply	Cold Supply	Number of Outlets
SH1	1st NW - Accessible Shower	Cal 1	Mains	1
SH2	1st SW - Left Shower	-	Mains	1
SH3	1st SW - Middle Shower	-	Mains	1
SH4	1st SW - Right Shower	-	Mains	1
SH5	2nd SW - Accessible Shower	Cal 1	Mains	1

Thermostatic Mixing Valves

Asset No.	Location	Hot Supply	Cold Supply	Approximate Number
TMV1	GF NW - Accessible WC	Cal 1	Mains	1
TMV2	GF NW - Female WC	Cal 1	Mains	1
TMV3	GF SW - Male WC	Cal 1	Mains	1
TMV4	1st NW - Female WC	Cal 1	Mains	1
TMV5	1st SW - Male WC	Cal 1	Mains	1
TMV6	1st SW - Accessible WC	Cal 1	Mains	1
TMV7	2nd NW - Accessible WC	Cal 1	Mains	1
TMV8	2nd NW - Female WC	Cal 1	Mains	1
TMV9	2nd SW - Male WC	Cal 1	Mains	1

Water Heaters

Appraisal of Water Systems

Asset No.	Location of heaters	Fed from	Storage	Number of outlets
WH1	1st PS - Kitchen	Mains	Low Storage Less 15 Ltrs	1
WH2	1st PS - Left Area	Mains	Low Storage Less 15 Ltrs	2
WH3	1st PS - Right Area	Mains	Low Storage Less 15 Ltrs	2

Other Water System on Site

Asset No.	Location	System Type	Fed From
FIL1	GF NW - Kitchen	Filters	Mains
Drinking Water Dispenser	GF NW - Kitchen	Drinking Water Dispensers / Ice Machines / Vending	Mains
FH1	GF NW - Kitchen	Flexible Hose Connectors	Domestic
SOT1	GF NW - Kitchen	Scale on Taps	Domestic
FH2	GF NW - Accessible WC	Flexible Hose Connectors	Domestic
SOT2	GF NW - Accessible WC	Scale on Taps	Domestic
FH3	GF NW - Female WC	Flexible Hose Connectors	Domestic
SOT3	GF NW - Female WC	Scale on Taps	Domestic
SOT4	GF NW - Cleaners	Scale on Taps	Domestic
FH4	GF SW - Male WC	Flexible Hose Connectors	Domestic
SOT5	GF SW - Male WC	Scale on Taps	Domestic
FIL2	GF SW - Kitchen	Filters	Mains
Drinking Water Dispenser	GF SW - Kitchen	Drinking Water Dispensers / Ice Machines / Vending	Mains
FH5	GF SW - Kitchen	Flexible Hose Connectors	Domestic
SOT6	GF SW - Kitchen	Scale on Taps	Domestic
FIL3	1st NW - Kitchen	Filters	Mains
Drinking Water Dispenser	1st NW - Kitchen	Drinking Water Dispensers / Ice Machines / Vending	Mains
FH6	1st NW - Kitchen	Flexible Hose Connectors	Domestic
SOT7	1st NW - Kitchen	Scale on Taps	Domestic
FH7	1st NW - Female WC	Flexible Hose Connectors	Domestic

Other Water System on Site

Asset No.	Location	System Type	Fed From
SOT8	1st NW - Female WC	Scale on Taps	Domestic
FH8	1st SW - Male WC	Flexible Hose Connectors	Domestic
SOT9	1st SW - Male WC	Scale on Taps	Domestic
FH9	1st SW - Accessible WC	Flexible Hose Connectors	Domestic
PV1	1st PS - Kitchen	Expansion / Pressure Vessels / Pump Accumulators	Mains
FIL4	1st PS - Kitchen	Filters	Mains
Drinking Water Dispenser	1st PS - Kitchen	Drinking Water Dispensers / Ice Machines / Vending	Mains
FH10	1st PS - Kitchen	Flexible Hose Connectors	Domestic
PV2	1st PS - Left Area	Expansion / Pressure Vessels / Pump Accumulators	Mains
FH11	1st PS - Left Area	Flexible Hose Connectors	Domestic
PV3	1st PS - Right Area	Expansion / Pressure Vessels / Pump Accumulators	Mains
FH12	1st PS - Right Area	Flexible Hose Connectors	Domestic
FIL5	2nd NW - Kitchen	Filters	Mains
Drinking Water Dispenser	2nd NW - Kitchen	Drinking Water Dispensers / Ice Machines / Vending	Mains
FH13	2nd NW - Kitchen	Flexible Hose Connectors	Domestic
SOT10	2nd NW - Kitchen	Scale on Taps	Domestic
SOT11	2nd NW - Cleaners	Scale on Taps	Domestic
FH14	2nd NW - Female WC	Flexible Hose Connectors	Domestic
SOT12	2nd NW - Female WC	Scale on Taps	Domestic
FH15	2nd SW - Male WC	Flexible Hose Connectors	Domestic

Appraisal of Water Systems

Other Water System on Site

Asset No.	Location	System Type	Fed From
SOT13	2nd SW - Male WC	Scale on Taps	Domestic
FIL6	2nd SW - Kitchen	Filters	Mains
Drinking Water Dispenser	2nd SW - Kitchen	Drinking Water Dispensers / Ice Machines / Vending	Mains
FH16	2nd SW - Kitchen	Flexible Hose Connectors	Domestic
SOT14	2nd SW - Kitchen	Scale on Taps	Domestic
FH17	2nd NW - Accessible WC	Flexible Hose Connectors	Domestic

Hot and Cold Water Outlets

Location
Refer to the schematic drawing for full location of hot and cold water outlets

Water Source

The water supply to a premises normally presents a low legionella risk due to the temperature of the incoming water which is generally well below control temperature. Even though legionella is a naturally occurring bacterium in the water, the relatively low temperature will render the bacteria dormant.

However, if the water supply is from an unusual source, for example a bore hole, natural wells, rain water harvesting system or even natural water bodies such as rivers and streams these may have the potential to contain debris and other factors could make bacterial proliferation a problem.

The investigation of any filtration systems and chemical treatment along with temperature profiling should give a good indicator of the risk of legionella.

Water source details are specified in the table below. Any actions required by site are detailed in Section 3.

Appraisal of Water Systems

	Asset No.	MAINS 1
	Location	Undetermined
Details	Mains Supply Stop Cock Location Serving Mains Supply Source	Undetermined Building Local Water Board
Material of Construction	Water Treatment In Place Temperature Of Mains Supply Supply Pipework Distribution Pipework Incoming Pipework Insulated Strainer Fitted Strainer Fitted Correctly Water Meter Installed Drinking Water Outlets Labelled WRAS Approved Materials	
Records	Chemical Dosing System Filtration System UV System	
	Temperatures	NC 8.0°C FC 9.0°C

Risk Rating	
System Risk	Low

Calorifier

Calorifiers present a low legionella risk, however when the calorifier supplies other associated plant which may have a high risk potential (e.g. showers etc.), the potential risk from such calorifiers is significantly higher.

Poor control over the water temperature and condition of the calorifier are the most significant factors in determining the risk presented by hot water calorifiers to the down water services.

Hot water systems details are specified in the table below. Any actions required by site are detailed in Section 3.

Appraisal of Water Systems

Asset No.	CAL 1
Location	2nd SW - Store
CAL Details	
Supplied from	Mains
Serving	Building
Time Of Inspection	00:00
Make and Model	Megaflo
Calorifier Orientation	Vertical
No of Calorifiers in System	1
Materials Of Construction	Stainless Steel
Capacity	115.0ltrs
Main Heat Source	Electric
Supplementary Heat Source	-
Temp & Flow	
Temperature Gauge Fitted To Calorifier / Flow	Yes
Temperature Gauge Fitted To Return	Yes
Calorifier Off Or On	On
Flow Temperature	58.0°C
Return Temperature	55.0°C
Calorifier Stratification	No
Calorifier Temperature Top	N/A
Calorifier Temperature Middle	N/A
Calorifier Temperature Bottom	N/A
Thermostat Setting	
Drain Fitted	Yes
Complete Draining Of Vessel Possible	Yes
Initial Blow down Appearance	Unable To Determine
Circulation & Insulation	
System Circulated	Yes
Pumps Alternated	N/A
Calorifier Insulation	Yes
Pipe Work Insulation	Yes
Pipe Work labelled	Yes
Open Vent Present	N/A
Safety Valve Present	Yes
Shunt Pump Fitted	N/A
Other Info	
WRAS Approved Materials	Yes
Suitable Capacity For System	Yes
Inspection Hatch Present	N/A
Suitable Access Present	Yes
Temperatures	NH 57.0°C FH 57.0°C

Risk Rating	
System Risk	High



Water Heaters

Low volume heaters present a lower legionella risk due to the fact that they store a small amount of water. These systems are typically found in smaller buildings such as domestic dwellings and small office buildings where cold water outlets are fed directly from the water supply without storage. Low volume water heaters heat a relatively small volume of water to the preset temperature and will only be suitable to supply a few outlets.

Water Heater details are specified in the table below. Any actions required by site are detailed in Section 3.

Appraisal of Water Systems

Asset No.	WH1
Location	1st PS - Kitchen
Water Heater Details	
Fed from	Mains
Heating Source	Electric
Storage	Low Storage Less 15 Ltrs
Power Supply To Units	On
Number Of Outlets	1
Max Temperature	63.0°C
WRAS Approved Materials	Yes
High Turn Over	Yes
Is Aerosol Likely	No
Condition Of Units Satisfactory	Yes
Temperatures	

Risk Rating	
System Risk	Low



Appraisal of Water Systems

Asset No.	WH2
Location	1st PS - Left Area
Water Heater Details	
Fed from	Mains
Heating Source	Electric
Storage	Low Storage Less 15 Ltrs
Power Supply To Units	On
Number Of Outlets	2
Max Temperature	58.0°C
WRAS Approved Materials	Yes
High Turn Over	Yes
Is Aerosol Likely	No
Condition Of Units Satisfactory	Yes
Temperatures	

Risk Rating	
System Risk	Low



Asset No.	WH3
Location	1st PS - Right Area
Water Heater Details	
Fed from	Mains
Heating Source	Electric
Storage	Low Storage Less 15 Ltrs
Power Supply To Units	On
Number Of Outlets	2
Max Temperature	51.0°C
WRAS Approved Materials	Yes
High Turn Over	Yes
Is Aerosol Likely	No
Condition Of Units Satisfactory	Yes
Temperatures	

Risk Rating	
System Risk	Low



Domestic Showers & Wash Outlets

As showers and spray outlets produce fine water droplets they present a significantly higher risk for the development of Legionnaires' disease than other types of hot and cold outlets. The most significant factors in determining the risk potential are water temperature, showerhead design, frequency of use and the cleanliness of the outlet.

Showers supplied via storage tanks, blending valves and temperature mixing valves pose greater risk of bacteria proliferation due to the design of the pipework with stagnated water stored in pipework prior to mixing.

Mains supplied electrical showers present a significantly lower risk of population by bacteria and dispersion due to the water source for this type of outlet. Although an aerosol is produced, the temperature of the water source should render any legionella bacteria dormant.

Shower details are specified in the table below. Any actions required by site are detailed in Section 3.

Appraisal of Water Systems

	Asset No.	SH1
	Location	1st NW - Accessible Shower
SH Details	Number of Outlets	1
	Fed From Hot	Cal 1
	Fed From Cold	Mains
	Type Of Shower	Thermostatic
Unit Type	Fixed Head	No
	Hose And Handset Type	Yes
	Connected To Bath	N/A
TMV Arrangement	Accessible	N/A
	At Each Individual Shower	N/A
	Supplying Multiple Showers	N/A
Showerhead Condition	Scale Present	No
	Algae Growth Present	No
	Usage - Frequently	Yes

Risk Rating	
System Risk	Low



Appraisal of Water Systems

	Asset No.	SH2
	Location	1st SW - Left Shower
SH Details	Number of Outlets	1
	Fed From Hot	-
	Fed From Cold	Mains
	Type Of Shower	Electric
Unit Type	Fixed Head	No
	Hose And Handset Type	Yes
	Connected To Bath	N/A
TMV Arrangement	Accessible	N/A
	At Each Individual Shower	N/A
	Supplying Multiple Showers	N/A
Showerhead Condition	Scale Present	No
	Algae Growth Present	No
	Usage - Frequently	Yes

Risk Rating	
System Risk	Low



Appraisal of Water Systems

Asset No.		SH3
Location		1st SW - Middle Shower
SH Details	Number of Outlets	1
	Fed From Hot	-
	Fed From Cold	Mains
	Type Of Shower	Electric
Unit Type	Fixed Head	No
	Hose And Handset Type	Yes
	Connected To Bath	N/A
TMV Arrangement	Accessible	N/A
	At Each Individual Shower	N/A
	Supplying Multiple Showers	N/A
Showerhead Condition	Scale Present	No
	Algae Growth Present	No
	Usage - Frequently	Yes

Risk Rating	
System Risk	Low



Appraisal of Water Systems

	Asset No.	SH4
	Location	1st SW - Right Shower
SH Details	Number of Outlets	1
	Fed From Hot	-
	Fed From Cold	Mains
	Type Of Shower	Electric
Unit Type	Fixed Head	No
	Hose And Handset Type	Yes
	Connected To Bath	N/A
TMV Arrangement	Accessible	N/A
	At Each Individual Shower	N/A
	Supplying Multiple Showers	N/A
Showerhead Condition	Scale Present	No
	Algae Growth Present	No
	Usage - Frequently	Yes

Risk Rating	
System Risk	Low



Appraisal of Water Systems

	Asset No.	SH5
	Location	2nd SW - Accessible Shower
SH Details	Number of Outlets	1
	Fed From Hot	Cal 1
	Fed From Cold	Mains
	Type Of Shower	Thermostatic
Unit Type	Fixed Head	No
	Hose And Handset Type	Yes
	Connected To Bath	N/A
TMV Arrangement	Accessible	N/A
	At Each Individual Shower	N/A
	Supplying Multiple Showers	N/A
Showerhead Condition	Scale Present	No
	Algae Growth Present	No
	Usage - Frequently	Yes

Risk Rating	
System Risk	Low



Thermostatic Mixing Valves

TMVs use a temperature sensitive element to blend hot and cold water to produce water at a temperature that safeguards against the risk of scalding. The mixed temperatures are typically set between 38°C and 46°C depending on outlet use. The blended water downstream of TMVs may provide an environment in which legionella can multiply, thus increasing the risks of exposure.

Where TMVs are fitted, consideration should be given to the following factors:

- | where practicable, TMVs should be incorporated directly in the tap fitting as mixing at the point of outlet is preferable;
- | the risk is increased where TMVs are fitted with low flow rate spray taps on hand washbasins;
- | TMV valves should be as close to the POU as possible to minimise the storage of blended water;
- | the risk can also be increased where a single TMV serves multiple tap outlets.

TMV details are specified in the table below. Any actions required by site are detailed in Section 3.

Appraisal of Water Systems

Asset No.	TMV1
Location	GF NW - Accessible WC
TMV Details	
Approximate Number	1
TMV Type	TMV Tap
Fed from Hot	Cal 1
Fed from Cold	Mains
Accessible	Yes
At Each Individual Outlet	Yes
Supplying Multiple Outlets	No
Number of outlets	1
Temperature	
Hot Supply To TMV Temperature	56.0°C
Cold Supply To TMV Temperature	8.0°C
Nearest Non-TMV Tap- Max Hot Temperature	N/A
Nearest Non-TMV Tap- Max Cold Temperature	N/A
TMV Outlet Temperature	42.0°C
Can TMV be moved closer to the POU	No
Can TMV be removed from system	No

Risk Rating	
System Risk	Low



Appraisal of Water Systems

	Asset No.	TMV2
	Location	GF NW - Female WC
TMV Details	Approximate Number	1
	TMV Type	TMV
	Fed from Hot	Cal 1
	Fed from Cold	Mains
	Accessible	Yes
	At Each Individual Outlet	No
	Supplying Multiple Outlets	Yes
	Number of outlets	4
Temperature	Hot Supply To TMV Temperature	56.0°C
	Cold Supply To TMV Temperature	8.0°C
	Nearest Non-TMV Tap- Max Hot Temperature	N/A
	Nearest Non-TMV Tap- Max Cold Temperature	N/A
	TMV Outlet Temperature	40.0°C
	Can TMV be moved closer to the POU	No
	Can TMV be removed from system	No

Risk Rating	
System Risk	Low



Asset No.	TMV3
Location	GF SW - Male WC
TMV Details	
Approximate Number	1
TMV Type	TMV
Fed from Hot	Cal 1
Fed from Cold	Mains
Accessible	Yes
At Each Individual Outlet	No
Supplying Multiple Outlets	Yes
Number of outlets	4
Temperature	
Hot Supply To TMV Temperature	56.0°C
Cold Supply To TMV Temperature	8.0°C
Nearest Non-TMV Tap- Max Hot Temperature	N/A
Nearest Non-TMV Tap- Max Cold Temperature	N/A
TMV Outlet Temperature	41.0°C
Can TMV be moved closer to the POU	No
Can TMV be removed from system	No

Risk Rating	
System Risk	Low



Appraisal of Water Systems

	Asset No.	TMV4
	Location	1st NW - Female WC
TMV Details	Approximate Number	1
	TMV Type	TMV
	Fed from Hot	Cal 1
	Fed from Cold	Mains
	Accessible	Yes
	At Each Individual Outlet	No
	Supplying Multiple Outlets	Yes
	Number of outlets	4
Temperature	Hot Supply To TMV Temperature	57.0°C
	Cold Supply To TMV Temperature	9.0°C
	Nearest Non-TMV Tap- Max Hot Temperature	N/A
	Nearest Non-TMV Tap- Max Cold Temperature	N/A
	TMV Outlet Temperature	38.0°C
	Can TMV be moved closer to the POU	No
	Can TMV be removed from system	No

Risk Rating	
System Risk	Low



Appraisal of Water Systems

	Asset No.	TMV5
	Location	1st SW - Male WC
TMV Details	Approximate Number	1
	TMV Type	TMV
	Fed from Hot	Cal 1
	Fed from Cold	Mains
	Accessible	Yes
	At Each Individual Outlet	No
	Supplying Multiple Outlets	Yes
	Number of outlets	4
Temperature	Hot Supply To TMV Temperature	56.0°C
	Cold Supply To TMV Temperature	8.0°C
	Nearest Non-TMV Tap- Max Hot Temperature	N/A
	Nearest Non-TMV Tap- Max Cold Temperature	N/A
	TMV Outlet Temperature	39.0°C
	Can TMV be moved closer to the POU	No
	Can TMV be removed from system	No

Risk Rating	
System Risk	Low



Appraisal of Water Systems

	Asset No.	TMV6
	Location	1st SW - Accessible WC
TMV Details	Approximate Number	1
	TMV Type	TMV Tap
	Fed from Hot	Cal 1
	Fed from Cold	Mains
	Accessible	Yes
	At Each Individual Outlet	Yes
	Supplying Multiple Outlets	No
	Number of outlets	1
Temperature	Hot Supply To TMV Temperature	55.0°C
	Cold Supply To TMV Temperature	10.0°C
	Nearest Non-TMV Tap- Max Hot Temperature	N/A
	Nearest Non-TMV Tap- Max Cold Temperature	N/A
	TMV Outlet Temperature	41.0°C
	Can TMV be moved closer to the POU	No
	Can TMV be removed from system	No

Risk Rating	
System Risk	Low



	Asset No.	TMV7
	Location	2nd NW - Accessible WC
TMV Details	Approximate Number	1
	TMV Type	TMV Tap
	Fed from Hot	Cal 1
	Fed from Cold	Mains
	Accessible	Yes
	At Each Individual Outlet	Yes
	Supplying Multiple Outlets	No
	Number of outlets	1
Temperature	Hot Supply To TMV Temperature	55.0°C
	Cold Supply To TMV Temperature	10.0°C
	Nearest Non-TMV Tap- Max Hot Temperature	N/A
	Nearest Non-TMV Tap- Max Cold Temperature	N/A
	TMV Outlet Temperature	40.0°C
	Can TMV be moved closer to the POU	No
	Can TMV be removed from system	No

Risk Rating	
System Risk	Low



Appraisal of Water Systems

	Asset No.	TMV8
	Location	2nd NW - Female WC
TMV Details	Approximate Number	1
	TMV Type	TMV
	Fed from Hot	Cal 1
	Fed from Cold	Mains
	Accessible	Yes
	At Each Individual Outlet	No
	Supplying Multiple Outlets	Yes
	Number of outlets	4
Temperature	Hot Supply To TMV Temperature	57.0°C
	Cold Supply To TMV Temperature	9.0°C
	Nearest Non-TMV Tap- Max Hot Temperature	N/A
	Nearest Non-TMV Tap- Max Cold Temperature	N/A
	TMV Outlet Temperature	39.0°C
	Can TMV be moved closer to the POU	No
	Can TMV be removed from system	No

Risk Rating	
System Risk	Low



	Asset No.	TMV9
	Location	2nd SW - Male WC
TMV Details	Approximate Number	1
	TMV Type	TMV
	Fed from Hot	Cal 1
	Fed from Cold	Mains
	Accessible	Yes
	At Each Individual Outlet	No
	Supplying Multiple Outlets	Yes
	Number of outlets	4
Temperature	Hot Supply To TMV Temperature	57.0°C
	Cold Supply To TMV Temperature	10.0°C
	Nearest Non-TMV Tap- Max Hot Temperature	N/A
	Nearest Non-TMV Tap- Max Cold Temperature	N/A
	TMV Outlet Temperature	42.0°C
	Can TMV be moved closer to the POU	No
	Can TMV be removed from system	No

Risk Rating	
System Risk	Low



Flexible Hose Connectors

Some materials such as polyethylene and ethylene-propylene found in under sink flexible hoses encourage colonisation and biofilm formation by a wide range of bacteria. Avoid materials that harbour bacteria and other micro-organisms, or provide nutrients for microbial growth. All materials used in the construction of systems should comply with the WRAS requirements or byelaws.

Flexible hose connectors details are specified in the table below. Any actions required by site are detailed in Section 3.

Appraisal of Water Systems

	Asset No.	FH1
	Location	GF NW - Kitchen
General	Satisfactory	No
Fed From	Fed From	Domestic
	Comments	-

Risk Rating	
System Risk	Medium



Appraisal of Water Systems

	Asset No.	FH2
	Location	GF NW - Accessible WC
General	Satisfactory	No
Fed From	Fed From	Domestic
	Comments	-

Risk Rating	
System Risk	Medium



Appraisal of Water Systems

	Asset No.	FH3
	Location	GF NW - Female WC
General	Satisfactory	No
Fed From	Fed From	Domestic
	Comments	-

Risk Rating	
System Risk	Medium



Appraisal of Water Systems

	Asset No.	FH4
	Location	GF SW - Male WC
General	Satisfactory	No
Fed From	Fed From	Domestic
	Comments	-

Risk Rating	
System Risk	Medium



Appraisal of Water Systems

	Asset No.	FH5
	Location	GF SW - Kitchen
General	Satisfactory	No
Fed From	Fed From	Domestic
	Comments	-

Risk Rating	
System Risk	Medium



Appraisal of Water Systems

	Asset No.	FH6
	Location	1st NW - Kitchen
General	Satisfactory	No
Fed From	Fed From	Domestic
	Comments	-

Risk Rating	
System Risk	Medium



Appraisal of Water Systems

	Asset No.	FH7
	Location	1st NW - Female WC
General	Satisfactory	No
Fed From	Fed From	Domestic
	Comments	-

Risk Rating	
System Risk	Medium



Appraisal of Water Systems

	Asset No.	FH8
	Location	1st SW - Male WC
General	Satisfactory	No
Fed From	Fed From	Domestic
	Comments	-

Risk Rating	
System Risk	Medium



Appraisal of Water Systems

	Asset No.	FH9
	Location	1st SW - Accessible WC
General	Satisfactory	No
Fed From	Fed From	Domestic
	Comments	-

Risk Rating	
System Risk	Medium



Appraisal of Water Systems

	Asset No.	FH10
	Location	1st PS - Kitchen
General	Satisfactory	No
Fed From	Fed From	Domestic
	Comments	-

Risk Rating	
System Risk	Medium



Appraisal of Water Systems

	Asset No.	FH11
	Location	1st PS - Left Area
General	Satisfactory	No
Fed From	Fed From	Domestic
	Comments	-

Risk Rating	
System Risk	Medium



Appraisal of Water Systems

	Asset No.	FH12
	Location	1st PS - Right Area
General	Satisfactory	No
Fed From	Fed From	Domestic
	Comments	-

Risk Rating	
System Risk	Medium



Appraisal of Water Systems

	Asset No.	FH13
	Location	2nd NW - Kitchen
General	Satisfactory	No
Fed From	Fed From	Domestic
	Comments	-

Risk Rating	
System Risk	Medium



Appraisal of Water Systems

	Asset No.	FH14
	Location	2nd NW - Female WC
General	Satisfactory	No
Fed From	Fed From	Domestic
	Comments	-

Risk Rating	
System Risk	Medium



Appraisal of Water Systems

	Asset No.	FH15
	Location	2nd SW - Male WC
General	Satisfactory	No
Fed From	Fed From	Domestic
	Comments	-

Risk Rating	
System Risk	Medium



Appraisal of Water Systems

	Asset No.	FH16
	Location	2nd SW - Kitchen
General	Satisfactory	No
Fed From	Fed From	Domestic
	Comments	-

Risk Rating	
System Risk	Medium



Appraisal of Water Systems

	Asset No.	FH17
	Location	2nd NW - Accessible WC
General	Satisfactory	No
Fed From	Fed From	Domestic
	Comments	-

Risk Rating	
System Risk	Medium



Expansion / Pressure Vessels / Pump Accumulators

When these units are incorporated into systems a dead leg is created to the pressurisation vessel. To minimise the dead leg created site should ensure the installation of these vessels are as close as possible to the system pipework.

Expansion and pressure vessel details are specified in the table below. Any actions required by site are detailed in Section 3.

Appraisal of Water Systems

	Asset No.	PV1
	Location	1st PS - Kitchen
General	Satisfactory	No
Fed From	Fed From	Mains
	Comments	-

Risk Rating	
System Risk	High



Appraisal of Water Systems

	Asset No.	PV2
	Location	1st PS - Left Area
General	Satisfactory	No
Fed From	Fed From	Mains
	Comments	-

Risk Rating	
System Risk	High



Appraisal of Water Systems

	Asset No.	PV3
	Location	1st PS - Right Area
General	Satisfactory	No
Fed From	Fed From	Mains
	Comments	-

Risk Rating	
System Risk	High



Scale on Taps

Scale was identified on some taps and this can act as a nutrient source for legionella bacteria.

Scale on tap details are specified in the table below. Any actions required by site are detailed in Section 3.

Appraisal of Water Systems

	Asset No.	SOT1
	Location	GF NW - Kitchen
General	Satisfactory	No
Fed From	Fed From	Domestic
	Comments	-

Risk Rating	
System Risk	Medium



Appraisal of Water Systems

	Asset No.	SOT2
	Location	GF NW - Accessible WC
General	Satisfactory	No
Fed From	Fed From	Domestic
	Comments	-

Risk Rating	
System Risk	Medium



Appraisal of Water Systems

	Asset No.	SOT3
	Location	GF NW - Female WC
General	Satisfactory	No
Fed From	Fed From	Domestic
	Comments	-

Risk Rating	
System Risk	Medium



Appraisal of Water Systems

	Asset No.	SOT4
	Location	GF NW - Cleaners
General	Satisfactory	No
Fed From	Fed From	Domestic
	Comments	-

Risk Rating	
System Risk	Medium



Appraisal of Water Systems

	Asset No.	SOT5
	Location	GF SW - Male WC
General	Satisfactory	No
Fed From	Fed From	Domestic
	Comments	-

Risk Rating	
System Risk	Medium



Appraisal of Water Systems

	Asset No.	SOT6
	Location	GF SW - Kitchen
General	Satisfactory	No
Fed From	Fed From	Domestic
	Comments	-

Risk Rating	
System Risk	Medium



Appraisal of Water Systems

	Asset No.	SOT7
	Location	1st NW - Kitchen
General	Satisfactory	No
Fed From	Fed From	Domestic
	Comments	-

Risk Rating	
System Risk	Medium



Appraisal of Water Systems

	Asset No.	SOT8
	Location	1st NW - Female WC
General	Satisfactory	No
Fed From	Fed From	Domestic
	Comments	-

Risk Rating	
System Risk	Medium



Appraisal of Water Systems

	Asset No.	SOT9
	Location	1st SW - Male WC
General	Satisfactory	No
Fed From	Fed From	Domestic
	Comments	-

Risk Rating	
System Risk	Medium



Appraisal of Water Systems

	Asset No.	SOT10
	Location	2nd NW - Kitchen
General	Satisfactory	No
Fed From	Fed From	Domestic
	Comments	-

Risk Rating	
System Risk	Medium



Appraisal of Water Systems

	Asset No.	SOT11
	Location	2nd NW - Cleaners
General	Satisfactory	No
Fed From	Fed From	Domestic
	Comments	-

Risk Rating	
System Risk	Medium



Appraisal of Water Systems

	Asset No.	SOT12
	Location	2nd NW - Female WC
General	Satisfactory	No
Fed From	Fed From	Domestic
	Comments	-

Risk Rating	
System Risk	Medium



Appraisal of Water Systems

	Asset No.	SOT13
	Location	2nd SW - Male WC
General	Satisfactory	No
Fed From	Fed From	Domestic
	Comments	-

Risk Rating	
System Risk	Medium



Appraisal of Water Systems

	Asset No.	SOT14
	Location	2nd SW - Kitchen
General	Satisfactory	No
Fed From	Fed From	Domestic
	Comments	-

Risk Rating	
System Risk	Medium



Filters

Filters are fitted to the pipework to remove organic matter and debris. Any build up of debris in the filter can provide an area in the system which may encourage the growth of bacteria.

Filter details are specified in the table below. Any actions required by site are detailed in Section 3.

Appraisal of Water Systems

	Asset No.	FIL1
	Location	GF NW - Kitchen
General	Satisfactory	Yes
Fed From	Fed From	Mains
	Comments	-

Risk Rating	
System Risk	Low



Appraisal of Water Systems

	Asset No.	FIL2
	Location	GF SW - Kitchen
General	Satisfactory	Yes
Fed From	Fed From	Mains
	Comments	-

Risk Rating	
System Risk	Low



Appraisal of Water Systems

	Asset No.	FIL3
	Location	1st NW - Kitchen
General	Satisfactory	Yes
Fed From	Fed From	Mains
	Comments	-

Risk Rating	
System Risk	Low



Appraisal of Water Systems

	Asset No.	FIL4
	Location	1st PS - Kitchen
General	Satisfactory	Yes
Fed From	Fed From	Mains
	Comments	-

Risk Rating	
System Risk	Low



Appraisal of Water Systems

	Asset No.	FIL5
	Location	2nd NW - Kitchen
General	Satisfactory	Yes
Fed From	Fed From	Mains
	Comments	-

Risk Rating	
System Risk	Low



Appraisal of Water Systems

	Asset No.	FIL6
	Location	2nd SW - Kitchen
General	Satisfactory	Yes
Fed From	Fed From	Mains
	Comments	-

Risk Rating	
System Risk	Low



Drinking Water Dispensers / Ice Machines / Vending

These systems are considered to be low risk as no aerosol is created during normal operation. The units are generally supplied by mains water and in regular use.

Details are specified in the table below. Any actions required by site are detailed in Section 3.

Appraisal of Water Systems

	Asset No.	Drinking Water Dispenser
	Location	GF NW - Kitchen
General	Satisfactory	Yes
Fed From	Fed From	Mains
	Comments	-

Risk Rating	
System Risk	Low



Appraisal of Water Systems

	Asset No.	Drinking Water Dispenser
	Location	GF SW - Kitchen
General	Satisfactory	Yes
Fed From	Fed From	Mains
	Comments	-

Risk Rating	
System Risk	Low



Appraisal of Water Systems

	Asset No.	Drinking Water Dispenser
	Location	1st NW - Kitchen
General	Satisfactory	Yes
Fed From	Fed From	Mains
	Comments	-

Risk Rating	
System Risk	Low



Appraisal of Water Systems

	Asset No.	Drinking Water Dispenser
	Location	1st PS - Kitchen
General	Satisfactory	Yes
Fed From	Fed From	Mains
	Comments	-

Risk Rating	
System Risk	Low



Appraisal of Water Systems

	Asset No.	Drinking Water Dispenser
	Location	2nd NW - Kitchen
General	Satisfactory	Yes
Fed From	Fed From	Mains
	Comments	-

Risk Rating	
System Risk	Low



Appraisal of Water Systems

	Asset No.	Drinking Water Dispenser
	Location	2nd SW - Kitchen
General	Satisfactory	Yes
Fed From	Fed From	Mains
	Comments	-

Risk Rating	
System Risk	Low



5 Testing of Water Systems

5.1 Water Temperature Measurements

OBJECTIVE To confirm that hot and cold water services are being maintained at temperatures which minimise the risk of proliferation of Legionella bacteria. The aim of the survey is to take a representative number of outlets to give an overall impression of the conditions within the distribution system. All other outlets should operate within the recommended temperature range.

METHOD Measurement of water temperature by the use of an electronic penetration and surface wet probe thermometer. The hot water temperatures recorded from those outlets that are supplied via thermostatic mixing valves (TMV) are taken from the hot and cold flow pipe work before the TMV. This gives the temperature of the water supplied to the TMV.

Where temperature is used as a control method, hot water shall be stored at a minimum of 60°C and distributed so it reaches a minimum temperature of 50°C within one minute at outlets. Where circulation is not possible, trace heating is sometimes used to maintain the water temperature in the spur so that it delivers at 50°C within one minute of running.

Number	Location	Source	Hot °C	S / NS	Source	Cold °C	S / NS	CWS >2°C from CWST
1	GF NW - Kitchen, RM	CAL 1	57°C	S	MAINS 1	8°C	S	N/A
2	GF SW - Kitchen, RM	CAL 1	56°C	S	MAINS 1	9°C	S	N/A
3	1st NW - Kitchen, RM	CAL 1	56°C	S	MAINS 1	9°C	S	N/A
4	1st PS - Kitchen, RM	WH1	63°C	S	MAINS 1	10°C	S	N/A
5	1st PS - Left Area, RM	WH2	58°C	S	MAINS 1	10°C	S	N/A
6	1st PS - Right Area, RM	WH3	51°C	S	MAINS 1	10°C	S	N/A
7	2nd NW - Kitchen, RM	CAL 1	57°C	S	MAINS 1	9°C	S	N/A
8	2nd NW - Female WC, RM	CAL 1	57°C	S	MAINS 1	9°C	S	N/A
Control parameters –		Cold ≤ 20°C within 2 minutes Hot ≥ 50°C within 1 minute Hot ≥ 50°C within 30 seconds for subordinate loops Hot ≥ 60°C water poses a risk to scalding if no TMV is fitted S = Satisfactory / NS = Not Satisfactory						

6 Appendices

6.1 List of Abbreviations and Acronyms

Standards and methods used in this report are taken from the most appropriate references available. Sources quoted are often given as abbreviations and acronyms and their full names are given here for easy reference.

ug/m ³	microgrammes per cubic metre
BMS	building management system
CAL	calorifier
cfu/l	colony forming units per litre
cfu/ml	colony forming units per millilitre
CHW	chilled water
COSHH	the control of substances hazardous to health regulations
CT	cooling tower
CWH	combination water heater
CWST	cold water storage tank
DCW	domestic cold water
DCWS	domestic cold water system
DHW	domestic hot water
DHWS	domestic hot water system
DE	dead end
DL	dead leg
FC	furthest cold
FH	furthest hot
GRP	glass reinforced plastic
HBE	health built environment
HSWA	the health & safety at work etc. act
IUO	infrequently used outlets
IWH	instant water heater
LPHW	low pressure hot water
mg/m ³	milligrammes per cubic metre
MSDS	material safety data sheets
MW	mains water
NWAM	non wras approved materials
ACS	air conditioning systems
AHU	air handling unit
AS	scrubber system
CD	chlorine dioxide unit
CH	chilled water
CHD	cyclone style hand dryer

Introduction

DC	dental chairs
EP	exposed pipe work
EUT	utility taps
FCA	fire control systems
FE	feed & expansion tank
FH	flexible hose connectors
FIL	filters
GW	grey water
HE	humidification equipment
INC	incubators
MB	mothballing
MT	lathes / machine tool systems
PAC	portable air conditioning systems
PPW	process production water
PU	pressurisation unit
PV	expansion / pressure vessels / pump accumulators
QFL	quick fill loops
RO	ro unit
RPZ	rpz valves
SOT	scale on taps
SP	swimming pools
SPA	spa baths
ST	spray taps
SPW	spray pressure washers
SR	strainers
SSS	safety shower & emergency eye wash
TSP	tanning spray booths
UV	uv light
VW	vehicle wash
WF	water feature
WP	water purification for dental chairs
WS	water softeners
N/A	not applicable

Appendices

DHCWS	domestic hot & cold water systems
NC	nearest cold
NH	nearest hot
PHE	plate heat exchanger
POU	point of use
ppb	parts per billion
ppm	parts per million
SH	shower/s
TMV	thermostatic mixing valves
TVC	total viable colonies
U/D	undetermined
UKAS	united kingdom accredited service
WH	water heater
WHB	wash hand basin
WMSoc	the water management society
WRAS	water regulations advisory scheme

6.2 Additional Certification



Legionella Control Association
KEEPING WATER SYSTEMS SAFE

Legionella Control Association

A Code of Conduct for Service Providers

Certificate of Registration

This is to certify that the following company has submitted a registration under the Conditions of Compliance as laid out in the LCA's Code of Conduct for Service Providers

Name of Company: HBE

Registration Number: 2008/1339 Certificate valid until: 31st August 2024

Registration under the following services categories:

- (1) Legionella Risk Assessment Services**
 - 1.1 Hot and Cold Water Systems Risk Assessment
 - 1.2 Evaporative Cooling Systems Risk Assessment
 - 1.3 Process and Other Systems Risk Assessment
 - 1.4 Healthcare Risk Assessment
- (2) Water Treatment Services**
 - 2.1 Hot and Cold Water Systems Water Treatment
 - 2.2 Evaporative Cooling Systems Water Treatment
 - 2.3 Process and Other Systems Water Treatment
- (3) Hot and Cold Water Monitoring and Inspection Services**
- (4) Cleaning and Disinfection Services**
 - 4.1 Hot and Cold Water Systems Cleaning and Disinfection
 - 4.2 Evaporative Cooling Systems Cleaning and Disinfection
 - 4.3 Process and Other Systems Cleaning and Disinfection
- (5) Independent Consultancy Services**
- (6) Training Services**
- (7) Legionella Monitoring Services**
 - 7.1 Sampling
 - 7.2 In Field Analysis
 - 7.4 Interpretation of Analysis
- (8) Plant and Equipment Services**
 - 8.1 Design and Supply
 - 8.2 Installation
 - 8.3 Servicing/maintenance
 - 8.4 Refurbishment

This Certificate is only valid if the Company named is listed on the LCA website www.legionellacontrol.org.uk/directory.php



THE WATER MANAGEMENT SOCIETY

Signed: 

Chairman, Executive Committee



Certificate Secretary



British Chemicals Association

Legionella Control Association Limited. www.legionellacontrol.org.uk

Registered in England and Wales No. 8502723

The legal duty to comply with relevant health and safety legislation (including avoidance or control of risk to exposure to Legionella bacteria) rests solely with the statutory dutyholder, being either the employer or the person in control of the premises or systems where any relevant risk is present, and this cannot be delegated. Specific functions (e.g. carrying out risk assessment) can be delegated and the Legionella Control Association (LCA) Code of Conduct is designed to help service providers, who also have duties under health and safety legislation, to establish appropriate management systems for the prevention or control of risk from Legionella bacteria. The LCA assesses the management systems of LCA members upon initial registration, reviews annually upon re-registration, and re-assesses by annual company audits. The LCA cannot and does not carry out other regular supervision of its members' commitments to the Code of Conduct nor their compliance with other LCA guidelines. A valid LCA certificate of registration (which is only valid if the Company named is listed on the LCA website www.legionellacontrol.org.uk/directory.php) confirms only that a service provider has satisfied LCA requirements at registration and its most recent company audit. It does not confirm the service provider's actual or continuing compliance with their commitments to the LCA Code of Conduct and/or other LCA guidelines. The LCA does not approve specific products or services as being effective in controlling Legionella or verify the competence of service providers' staff and sub-contractors, which is the duty of the service provider and the statutory dutyholder. The LCA accepts no liability for any omission or any act carried out in reliance on the LCA Code of Conduct or other LCA guidelines, or any loss or damage resulting from non-compliance with such documents.

6.3 Schematic Drawings

Schematic drawings have been completed as part of the HBE risk assessment; these are attached at the back of the report.

6.4 Legionella Escalation Procedure

Sampling is routinely completed to confirm the effectiveness of the risk management program for Legionella control. A suitably accredited laboratory (UKAS accredited for *Legionella* analysis) completes the laboratory analysis. This provides information on the effectiveness of the control program and indicates whether further assessment of the risk is necessary. More frequent Legionella sampling may be required from areas of high risk, e.g. Elderly Persons Homes, Hospital Wards with High Risk Patients, or other high risk systems such as Cooling Towers or Spa Baths.

For *Legionella* sampling the table below outlines the actions to be taken in accordance with the guidelines laid down in the "HSE document L8 – *Legionnaires' Disease, The control of legionella bacteria in water systems: Approved Code of Practice and Guidance* and HPSC, Health Protection Surveillance Centre, *National Guidelines for the Control of Legionellosis in Ireland 2009 (Please note that this document is not relevant within a healthcare Environment)*.

Legionella Bacteria (cfu/l)	Action
Not Detected	System under control, inform Responsible Person, file results and maintain current control regime.
Up to 100 cfu/l	<p>Inform Responsible Person</p> <p>In healthcare, the primary concern is protecting susceptible patients, so any detection of Legionella must be investigated and, if necessary, the system resampled to aid interpretation of the results in line with the monitoring strategy and risk assessment.</p> <p>File results and record any communication with Responsible Person.</p>
>100 cfu/l and up to 1000 cfu/l	<p>Inform Responsible Person and</p> <p>Either</p> <ul style="list-style-type: none"> ▫ if the minority of samples are positive, the system must be resampled. If similar results are found again, review the control measures and risk assessment to identify any remedial actions necessary or; ▫ if the majority of samples are positive, the system may be colonised, albeit at a low level. An immediate review of control measures and a risk assessment must be carried out to identify any other remedial action required. Disinfection of the system must be considered. <p>File results and record any communication with Responsible Person.</p>
>1000 cfu/l	<p>Inform Responsible Person</p> <p>The system must be resampled and an immediate review of the control measures and risk assessment carried out to identify any remedial actions, including possible disinfection of the system. Retesting must take place a few days after disinfection and at frequent intervals thereafter until a satisfactory level of control is achieved.</p> <p>File results and record any communication with Responsible Person.</p>

6.5 Action to take if there is an outbreak of Legionellosis

1. In England and Wales, legionnaires' disease is notifiable under the Health Protection (Notification) Regulations 2010 and in Scotland under the Public Health (Notification of Infectious Diseases) (Scotland) Regulations 1988 and in Northern Ireland under the Health Protection Agency Order 2007. Under these Regulations, human diagnostic laboratories must notify Public Health England (PHE), Public Health Wales (PHW) or Health Protection Scotland (HPS) and Public Health Agency (PHA) Northern Ireland (see 'Further sources of advice') of microbiologically confirmed cases of legionnaires' disease.
2. An outbreak is defined as two or more cases where the onset of illness is closely linked in time (weeks rather than months) and where there is epidemiological evidence of a common source of infection, with or without microbiological evidence. An incident/outbreak control team must always be convened to investigate outbreaks. It is the responsibility of the Proper Officer to declare an outbreak. The Proper Officer, appointed by the Local Authority, is usually a Consultant in Communicable Diseases Control (CCDC) in England and Wales, or the Consultant in Public Health Medicine (CPHM) in Scotland. If there are suspected cases of the disease, medical practitioners must notify the Proper Officer in the relevant local authority.
3. Local Authorities will have jointly established incident plans to investigate major outbreaks of infectious diseases, including legionellosis, and it is the Proper Officer who activates these and invokes an Outbreak Committee, whose primary purpose is to protect public health and prevent further infection.
4. HSE (UK) or local Environmental Health Officers may be involved in the investigation of outbreaks, their aim being to pursue compliance with health and safety legislation. The local authority, Proper Officer or EHO acting on their behalf will make a visit for public health reasons, often with the relevant officer from the enforcing authorities (i.e. HSE (UK) or the local authority) for health and safety reasons. Any infringements of relevant legislation may be subject to a formal investigation by the appropriate enforcing authority.
5. There are published guidelines (by PHE, PHW and HPS) for the investigation and management of incidents, clusters, and outbreaks of Legionnaires' disease in the community.
6. These are, for England and Wales, Guidance on the Control, and Prevention of Legionnaires' Disease in England and for Scotland, Guidelines on Management of Legionella Incidents, Outbreaks and Clusters in the Community.
7. If a water system is implicated in an outbreak of Legionnaires' disease, emergency treatment of that system must be carried out as soon as possible. This will usually involve the processes detailed in paragraphs 2.124–2.135.
8. In the Republic of Ireland (ROI), the director of public health (DPH)/consultant in public health medicine (CPHM) must:
 1. Arrange appropriate epidemiological investigation of a case or outbreak of legionnaires' disease.
 1. This must be done in liaison with the clinical microbiologist where one is employed
 1. Inform HPSC of a case or outbreak of legionellosis
 1. Inform the HSA of a case or outbreak of legionellosis
 1. Ensure relevant clinicians and general practitioners (GPs) in the area are informed of a case or outbreak where appropriate.

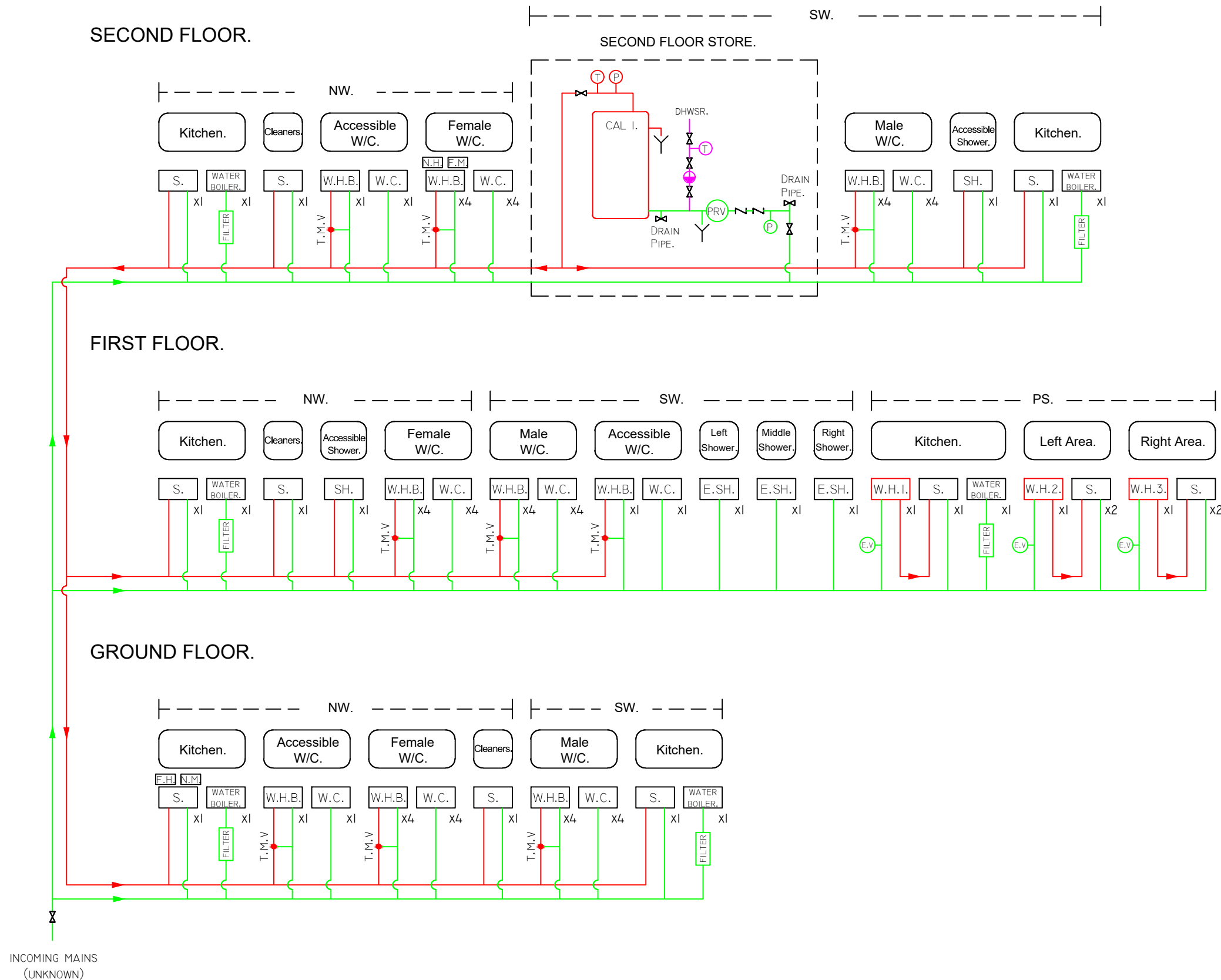

SENTINELS.		LEGEND.	
F.H.	FURTHEST HOT.	RPZ	REDUCED PRESSURE ZONE
F.M.	FURTHEST MAINS.	T	TEMP GAUGE.
F.C.	FURTHEST COLD.		
N.H.	NEAREST HOT.		
N.M.	NEAREST MAINS.		
N.C.	NEAREST COLD.		
M.	METER.	Y	TUNDISH.
L.V.	LID VENT.	⊥	RODENT SCREEN.
S.L.	SECURED LID.	⊥	ISOLATION VALVE.
D.L.	DEAD LEG.	D.E.	DEAD END.
P	PRESSURE GAUGE.	HYDRO BOILER	HYDRO BOILER.
PV	PRESSURE VESSEL.	⊥	ISOLATION VALVE (OPEN)
	PRESSURE REDUCE VALVE.	⊥	ISOLATION VALVE (CLOSED)
W.H.B.	WASH HAND BASIN.	⊥	PRESSURE REGULATE VALVE.
S.	SINK.	⊥	DRAIN COCK.
W.C.	TOILET UNIT.	⊥	RETURN PUMP.
U.	URINAL.	⊥	SHUNT PUMP.
SH.	SHOWER.	⊥	NON-RETURN VALVE.
E.SH.	ELECTRIC SHOWER.	⊥	STRAINER.
TAP.	TAP.	D.W.D.	DRINK WATER DISPENSER.
SL.	SLUICE SINK.	FLEXI.	FLEXI-HOSE.
D.F.	DRINKING FOUNTAIN.	⊥	CHECK VALVE.
W.M.	WASHING MACHINE.	⊥	DOUBLE CHECK VALVE.
D.W.	DISH WASHER.	PU	PRESSURISATION UNIT.
W.H.	WATER HEATER.	QF	QUICK FILL.
I.W.H.	INSTANT WATER HEATER.	D.W.D.	DRINK WATER DISPENSER.
FILTER	FILTER.	⊥	PRESSURE RELIEF VALVE.
WD SH.	WASH DOWN SHOWER.	⊥	
I.U.O.	INFREQUENTLY USED OUTLET		
EXP.	EXPOSED PIPE WORK		
U/D.	UNDETERMINED		
HEATING ELEMENTS			
(E)	(S)	(G)	
ELECTRICAL	SOLAR	GAS	
—	—	—	
COLD WATER FLOW		HOT WATER FLOW	
—		—	
MAIN WATER FLOW		RETURN WATER FLOW	
▶	DIRECTIONAL FLOW.		
T.M.V.	Thermostatic Mixing Valve	⊥	Thermostatic Mixing Tap
CLIENT: Believe Housing.			
PROJECT: LEGIONELLA RISK ASSESSMENT 4 Spectrum Business Park, Seaham, Durham, SR7 7TT, England.			
DRAWING: SCHEMATIC LAYOUT. (1 of 1)			
DATE:	HBE REF:	VERSION:	DRAWN BY:
02/24	664702	V2	T.K

COAST HOUSE SPECTRUM.

HBE Schematics are a representation of the water system. The surveyor uses his/her experience to determine which source supplies the relevant outlet/s. For accurate information on which source supplies each outlet HBE would recommend a dye test is undertaken.

The Frontline Skills Framework - Utilities (5831) - Legionella

is awarded to
Carleton Waite

who attended
Develop Training Limited

This holder has a number of formal Unit Credits by which this Award was achieved

It is recommended that this qualification is renewed after a period of three years

Awarded 24 November 2015

241115/5831-54/023703/TFI3290/M/01/04/89

5501567602/40



Sir John Armitt, CBE FREng FCGI
Chairman
The City and Guilds of London Institute



Chris Jones
Director-General
The City and Guilds of London Institute

C001



CERTIFICATE OF UNIT CREDIT TOWARDS

The Frontline Skills Framework - Utilities (5831) - Legionella

is awarded to
Carleton Waite

who attended
Develop Training Limited

and was successful in the following module

Risk assessment of hot and cold water systems in buildings

Pass

Awarded 24 November 2015

241115/5831-54/023703/TFI3290/MI/01/04/89

5501567602/600

Sir John Armitth, CBE FREng FCGI
Chairman
The City and Guilds of London Institute

Chris Jones
Director-General
The City and Guilds of London Institute

RO1

